

c面: 外表面.

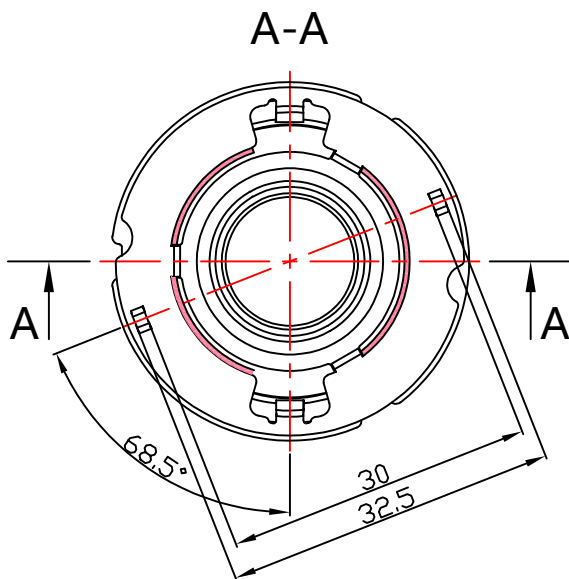

LIGHT SOURCE	LUMILEDS 1202HD
PLASTIC HOLDER	92.70.409.00
METAL ADAPTAR	
DESIGNED B.A.	$50^\circ \pm 5^\circ$
MEASURED B.A.	54.2°
EFFICIENCY	

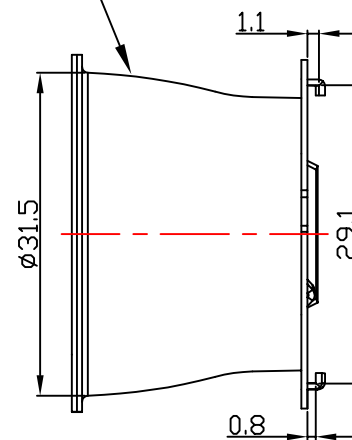
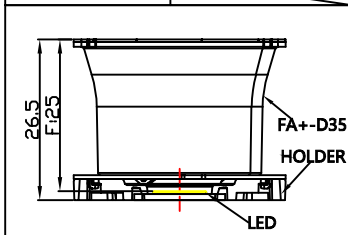

Technical requirements:

- 1.***KEY CONTROL DIMENSION.
- 2.Tolerances not noted are in accordance with the tolerance table.
- 3.unmarked rounded corners Press for 3D.
- 4.Surface without imprint, black spots, cracks, wrinkles and other poor.

PRODUCT BOM

NO.	PRODUCT NAME	P/N:	QUANTITY	MATERIAL/FINISH
①	1-1200-M卡扣	97.77.072.00	1	T=0.6mm SUS301
②	1-1276-A	94.01.1276.000	1	T=0.6mm 1070AL/Anodizing
③	1-1277-A	94.01.1277.000	1	T=0.4mm High reflectivity aluminum(Mirror surface)

标记	处数	更改内容	签名	更改日期
MARK	NO.OF MODIF	MODIFICATIONS	SIGNED BY	MODIF. DATE
设计	制图	比例	审核	日期
DESIGNER	DRAWN BY	SCALE	CHECKED BY	DATE(DD-MM-YYYY)
工艺	日期	日期	日期	日期
TECHNICAN	DATE(DD-MM-YYYY)	DATE(DD-MM-YYYY)	DATE(DD-MM-YYYY)	DATE(DD-MM-YYYY)
批准	29-09-2022	29-09-2022	29-09-2022	29-09-2022
APPROVED BY				

DIMENSION TOLERANCE TABLE (UNLESS OTHERWISE STATED)							
> 0-5	> 5-30	> 30-90	> 90-150	> 150-250	> 250-400	> 400-700	
±0.15	±0.2	±0.4	±0.5	±0.8	±1.5	±2	
PUNCH TOLERANCE TABLE (UNLESS OTHERWISE STATED) (ANGLE)							
> 0-10	> 10-50	> 50-120	> 120-250	> 250-360			
±1°	±0.5°	±0.3°	±0.2°	±0.166°			

		版本	K
		VERSIONS	
产品编码	91.01.1376.000	客户代号	NT
PRODUCT CODE		CUSTOMER ID	
产品名称	1-1376-L	客户编号	FA+-35-50D
PRODUCT NAME		CUSTOMER CODE	

产品图
PRODUCT DRAWING

单位
UNIT
mm

1:1

SHEET 1 OF 1